



Dongguan BEST motor co., LTD

BTF50 Series Crossflow Blowers

Brief Introductions:

Wheel: Aluminum Alloy
 Housing: Galvanized Sheet or E-Coating
 Motor Type: Shaded Pole Motors BTF63 Series (can be others)
 Bearing: Ball Bearing or Bronze Sleeve
 Power Supply: 100-240VAC As Request

Insulation System: Class E,B,F or H As Request
 Operating Temperature: -10°C To +50°C
 Overheating Protection: T.P. or Z.P.
 Electrical Connection: Flat-pin Terminal or Lead Wire
 RoHS Compliance: As Needed

Outline Dimensions (All dimensions in millimeters)

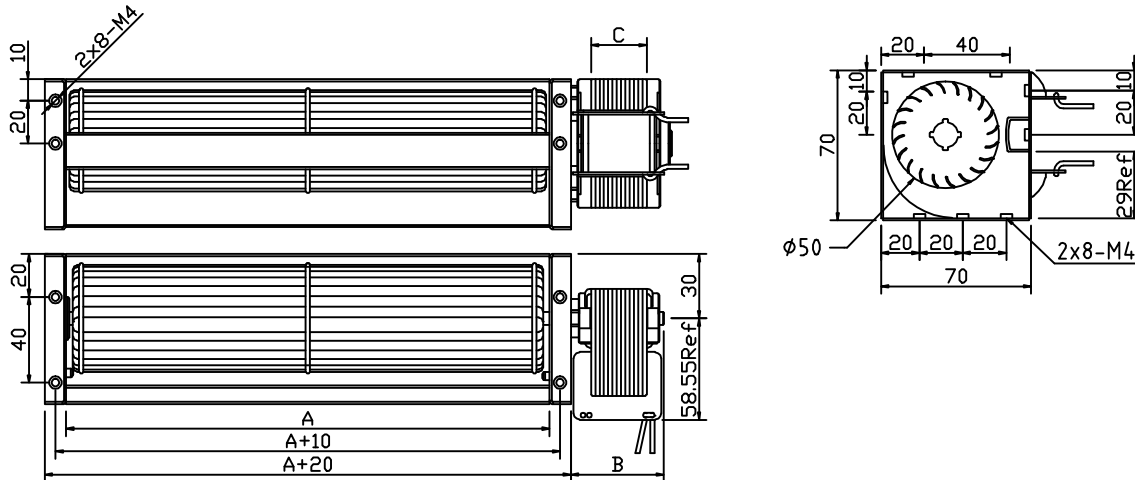

Technical Performances (based on free air conditions)

NO.	Specifications Model	Power Supply		Input Power	Output Speed	Max.Airflow		Max.Static Pressure		Noise Level	Dimensions		
		Volts	Freq'y			Metric	American	Metric	American		A	B	C
		(VAC)	(Hz)	(Watts)	(rpm)	(m ³ /h)	(CFM)	(PA)	(in H ₂ O)	(dB(A))	(mm)		
1	BTF50200-SP6315	230	50	15	2000	100	59	37	0.1487	42	200	42	15
		120	60	15	2200	110	65	40	0.1608	45			
2	BTF50250-SP6320	230	50	22	2000	120	71	37	0.1487	43	250	47	20
		120	60	22	2200	130	77	40	0.1608	45			
3	BTF50300-SP6325	230	50	30	2000	135	80	38	0.1528	43	300	52	25
		120	60	30	2200	150	89	40	0.1608	46			
4	BTF50350-SP6330	230	50	38	2000	160	95	40	0.1608	43	350	57	30
		120	60	38	2200	180	107	42	0.1688	47			

Characteristics Curve

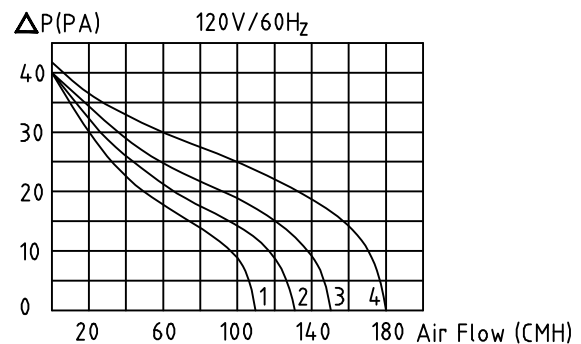
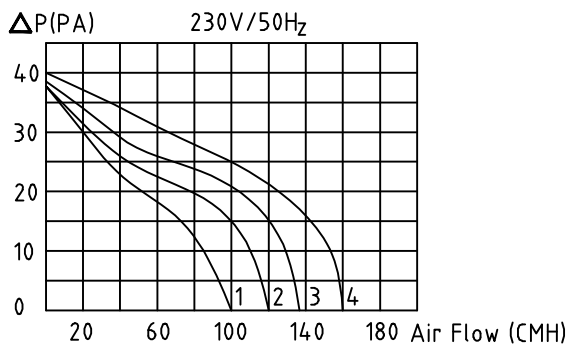

- ×Function type is optional.
- ×The max. air flow and the speed are measured in free air ; max.air pressure is measured at zero air flow.
- ×Noise is measured in anechoic chamber in free air,one meter from intake side.
- ×All readings are typical values at rated voltage.
- ×Specifications are subject to change without notice.

Address: No.88 Baihua Road,Baihuadong Village ,Dalingshan Town,Dongguan,Guangdong.

Mobile: 13823111573 13926873158

Tel: 86-769-33217056 33217059

FAX: 86-769-82761650

QQ: 343315716 303294997

E-mail: betterfan@163.com bestfan2118@163.com

Web site: WWW.bestfan888.com