

SM4001 THRU SM4007



TECHNICAL SPECIFICATIONS OF SURFACE MOUNT SILICON RECTIFIER

VOLTAGE RANGE - 50 to 1000 Volts

CURRENT - 1.0 Ampere

FEATURES

- * Ideal for surface mounted applications
- * Low leakage current
- * Glass passivated junction

MECHANICAL DATA

- * Case: Molded plastic
- * Epoxy: UL 94V-0 rate flame retardant
- * Terminals: Solder plated solderable per MIL-STD-202E, Method 208 guaranteed
- * Polarity: Color band denotes cathode end
- * Mounting position: Any
- * Weight: 0.12 gram



SM-1(DO-213AB)

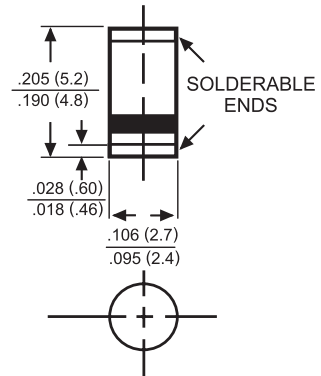

Dimensions in inches and (millimeters)

MAXIMUM RATINGS AND ELECTRICAL CHARACTERISTICS

Ratings at 25 °C ambient temperature unless otherwise specified.
Single phase, half wave, 60 Hz, resistive or inductive load.
For capacitive load, derate current by 20%.

	SYMBOL	SM4001	SM4002	SM4003	SM4004	SM4005	SM4006	SM4007	UNITS
Maximum Recurrent Peak Reverse Voltage	V _{RRM}	50	100	200	400	600	800	1000	Volts
Maximum RMS Voltage	V _{RMS}	35	70	140	280	420	560	700	Volts
Maximum DC Blocking Voltage	V _{DC}	50	100	200	400	600	800	1000	Volts
Maximum Average Forward Rectified Current T _A = 75°C	I _O	1.0							Amps
Peak Forward Surge Current I _{FM} (surge): 8.3 ms single half sine-wave superimposed on rated load (JEDEC Method)	I _{FSM}	30							Amps
Maximum Forward Voltage at 1.0A DC	V _F	1.1							Volts
Maximum DC Reverse Current at	I _R	@T _A = 25°C	5.0						uAmps
Rated DC Blocking Voltage		@T _A = 125°C	50						
Maximum Thermal Resistance (Note 2)	R _{θJL}	20							°C/W
Typical Junction Capacitance (Note 1)	C _J	15							pF
Operating and Storage Temperature Range	T _J , T _{STG}	-65 to + 175							°C

- NOTES : 1. Measured at 1.0 MHz and applied reverse voltage of 4.0VDC
2. Thermal resistance (Junction to Ambient), .24in² (6.0mm²) copper pads to each terminal.

FIG. 1 - TYPICAL FORWARD CURRENT DERATING CURVE

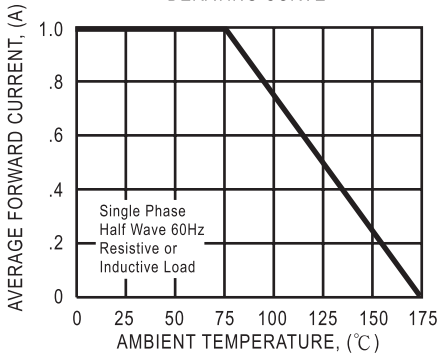

FIG. 2 - MAXIMUM NON-REPETITIVE FORWARD SURGE CURRENT

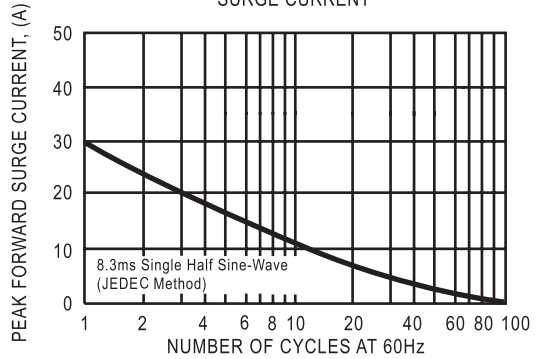

FIG. 3 - TYPICAL INSTANTANEOUS FORWARD CHARACTERISTICS

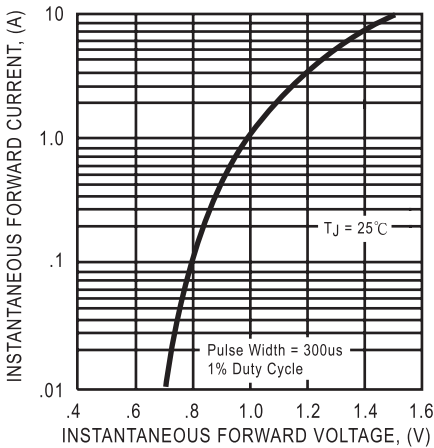

FIG. 4 - TYPICAL REVERSE CHARACTERISTICS

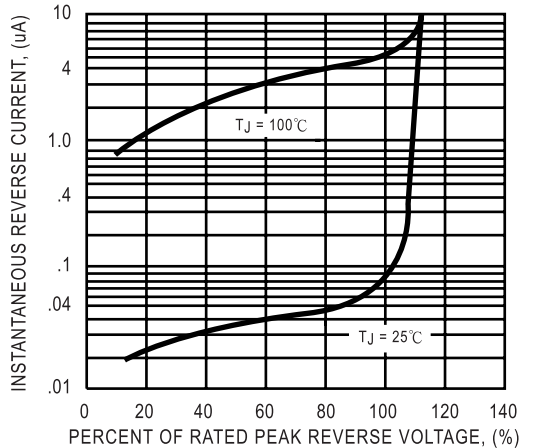

FIG. 5 - TYPICAL JUNCTION CAPACITANCE

