

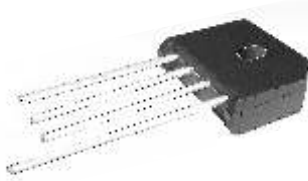

RS801 thru RS807

8.0 A Single-Phase Silicon Bridge Rectifier Rectifier Reverse Voltage 50 to 1000V



Features

- This series is UL listed under the Recognized Component Index, file number E142814
- Single In-Line terminals array suitable for P.C. board mounting
- Surge overload ratings to 300 amperes peak
- The plastic material used carries Underwriters Laboratory flammability recognition 94V-0
- High temperature soldering guaranteed 265°C/10 seconds/.375"(9.5mm) lead length at 5 lbs (2.3kg) tension

Mechanical Data

Case: Molded plastic
 Terminals: Plated wire leads solderable per MIL-STD-202, Method 208
 Mounting Position: Any
 Mounting Torque: 5 in-lb maximum
 Weight: 0.3 ounce, 8 grams (approx)

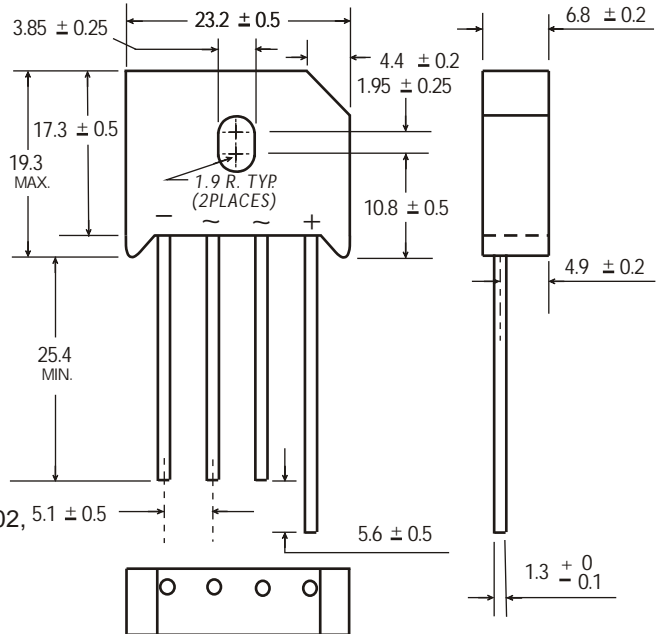

Dimensions in millimeters(1mm = 0.0394")

Maximum Ratings & Thermal Characteristics

Rating at 25°C ambient temperature unless otherwise specified, Resistive or Inductive load, 60 Hz.
 For Capacitive load derate current by 20%.

Parameter	Symbol	RS801	RS802	RS803	RS804	RS805	RS806	RS807	unit
Maximum repetitive peak reverse voltage	VRRM	50	100	200	400	600	800	1000	V
Maximum RMS bridge input voltage	VRMS	35	70	140	280	420	560	700	V
Maximum DC blocking voltage	VDC	50	100	200	400	600	800	1000	V
Maximum average forward rectified output current at T _C =100°C T _C =45°C	IF(AV)				8.0 6.0				A
Peak forward surge current single sine-wave superimposed on rated load (JEDEC Method)	IFSM				300				A
Rating for fusing (t < 8.3ms)	I ² t				373				A ² sec
Typical thermal resistance per element (1)	ReJA				2.5				°C / W
Operating junction and storage temperature range	T _J , T _{STG}				-55 to + 150				°C

Electrical Characteristics

Rating at 25°C ambient temperature unless otherwise specified. Resistive or Inductive load, 60Hz.
 For Capacitive load derate by 20 %.

Parameter	Symbol	RS801	RS802	RS803	RS804	RS805	RS806	RS807	Unit
Maximum instantaneous forward voltage drop per leg at 8.0A	VF				1.1				V
Maximum DC reverse current at rated DC blocking voltage per element T _A = 25°C T _A = 125°C	I _R				10 1000				μA

Notes: (1) Thermal resistance from Junction to Ambient on P.C. board mounting.



Rating and Characteristic Curves ($T_A=25^{\circ}\text{C}$ Unless otherwise noted)
RS801 thru RS807

Fig. 1 Derating Curve for Output Rectified Current

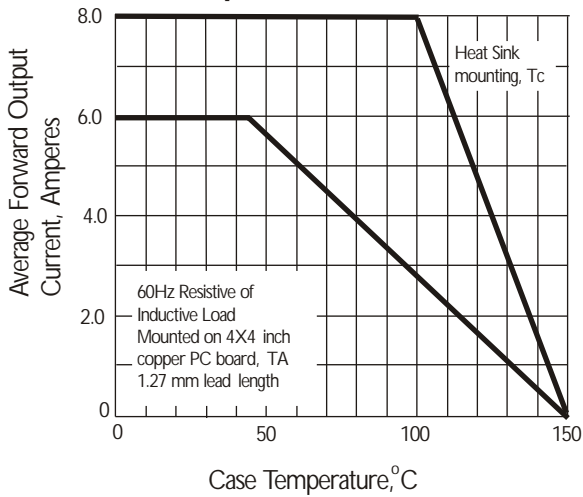

Fig. 2 Maximum Non-repetitive Peak Forward Surge Current

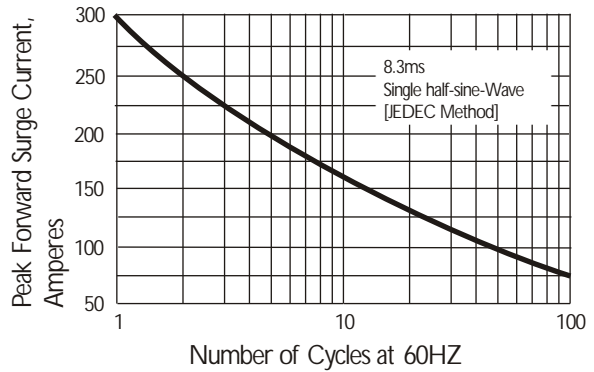

Fig. 3 Typical Instantaneous Forward Characteristics

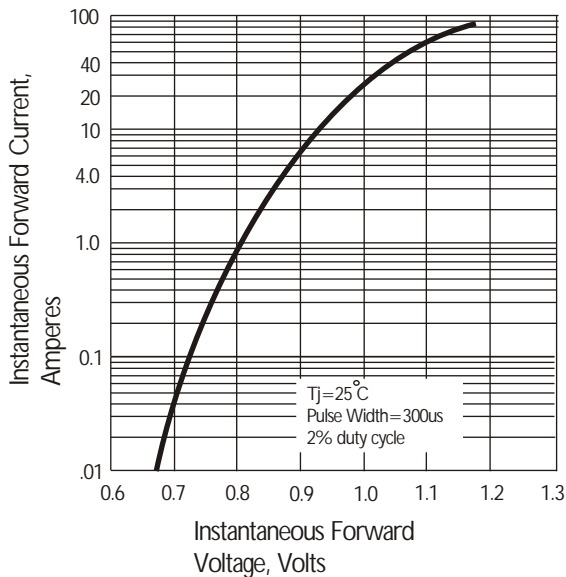

Fig. 4 Typical Reverse Characteristics

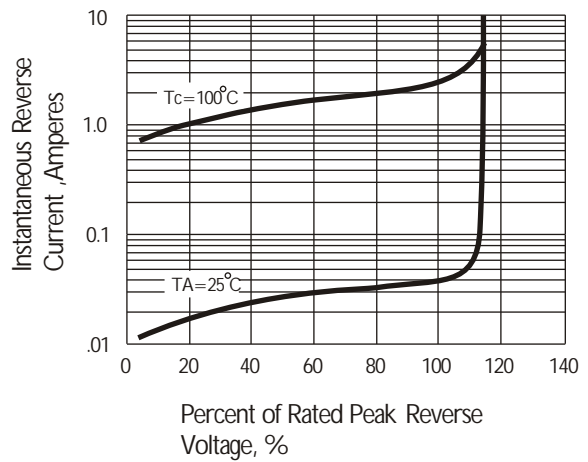

Fig. 5 Typical Junction Capacitance

