

* FOR LED BACKLIGHT
 T1=14.0MAX T2=9.0±0.3
 * FOR EL OR NO BACKLIGHT
 T1=11.0MAX T2=6.0±0.3

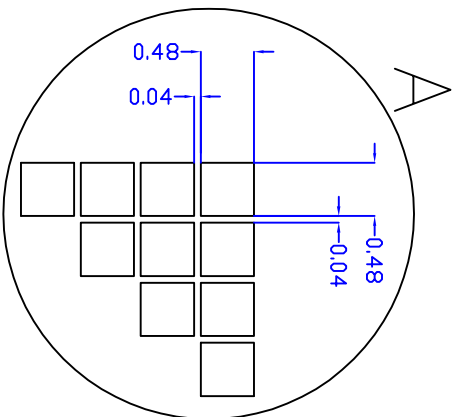

REVISIONS

NO.	DATE	BY	DESCRIPTION
1	01/06/18	NLV	NEW RELEASE

PINS ASSIGNMENT

NO.	SYMBOL	DESCRIPTION
1	VSS	GROUND
2	VDD	POWER SUPPLY FOR LOGIC AND LCD
3	VO	CONTRAST ADJUST
4	RS	DATA/INSTRUCTION SELECT
5	R/W	READ/WRITE SELECT
6	E	ENABLE SIGNAL
7--14	DB0--DB7	DATA BUS
15	PSB	PARALLEL/SERIAL INTERFACE SELECTION
16	NC	NO CONNECT
17	/RST	RESET SIGNAL(LOW EFFECTIVE)
18	NC	NO CONNECT
19	A	POWER SUPPLY FOR LED BACKLIGHT(+)
20	K	POWER SUPPLY FOR LED BACKLIGHT(-)

ABSOLUTE MAXIMUM RATING

ITEM	SYMBOL	MIN	MAX	UNIT
POWER SUPPLY(LOGIC)	VDD-VSS	0	6.5	V
POWER SUPPLY(LCD DRV)	VDD-V0	0	18.0	V
INPUT VOLTAGE	VI	VI	VDD	V

ELECTRICAL CHARACTERISTICS

ITEM	SYMBOL	MIN	TYP	MAX	UNIT
VOLTAGE FOR LOGIC	VDD-VSS	4.75	5.0	5.25	V
SUPPLY CURRENT	IDD	-	8.7	-	mA
LCD OPERATING VOLTAGE	V0	-	4.0	-	V
INPUT VOLTAGE	VI	0.2VDD	-	VDD	V
WHITE LED VOLTAGE	VLED	-	3.1	3.5	V

MECHANICAL SPECIFICATIONS

ITEM	SPECIFICATION	UNIT
OVERALL SIZE	93.0W x 70.0H x 14.0T(11.0T)	MM
VIEWING AREA	72.0W x 40.0H	MM
DOT NUMBER	128 x 64	DOTS
DOT SIZE	0.48W x 0.48H	MM
DOT PITCH	0.52W x 0.52H	MM

OPTIONS

- LCD TYPE: Y/G STN; GRAY STN; B/W FSTN
- BACKLIGHT: WITHOUT BACKLIGHT; LED; EL
- COLOR OF BACKLIGHT: Y/G; BLUE; WHITE
- TEMPERATURE RANGE: NORMAL(0--50C); EXTENDED(-20--70C)
- POWER SUPPLY: ON BOARD DC/DC(SINGLE 5.0V); DUAL POWER SUPPLY(5.0V & -10.0V)
- VIEWING ANGLE: 6H; 12H

NLV-G1286416A

128 X 64 DOTS GRAPHICS LCM



奈立微科技有限公司

NLV YOUR SUPPLIER AND YOUR PARTNER!

ALL DIMENSIONS ARE IN MM. TOLERANCE IS +/-0.2 UNLESS OTHERWISE NOTED.

