

DM12232A

*122x32DOTS 1/32Duty 1/6Bias
Yellow-Green mode STN Transflective

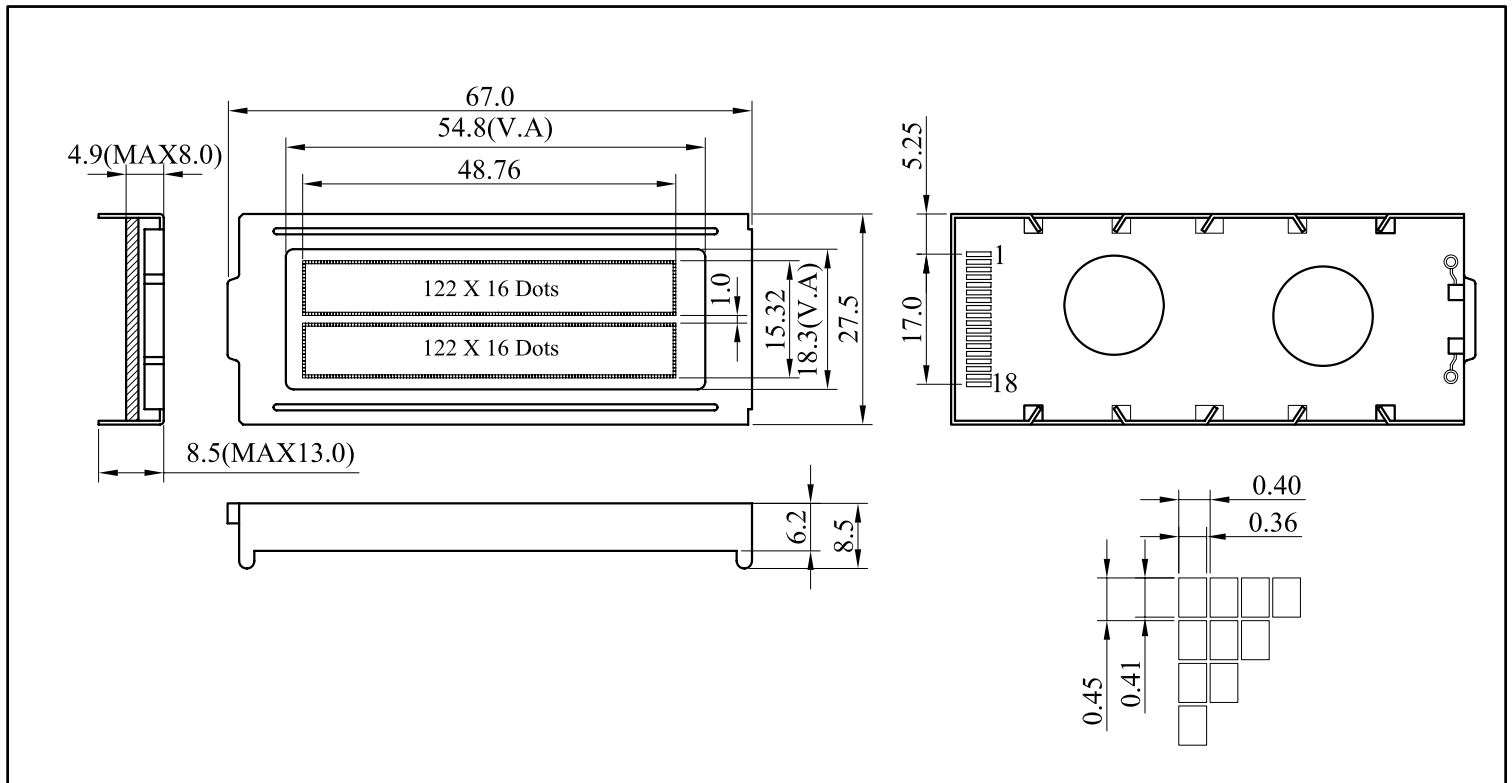

ABSOLUTE MAXIMUM RATINGS

Item	Symbol	Min.	Max.	Unit
Supply Voltage(Logic)	Vdd - Vss	-0.3	5.5	V
Supply Voltage(LCD)	Vdd - V0	-0.3	+5.0	V
Input Voltage	Vi	-0.3	Vdd + 0.3	V
Operating Temp.	Topr	-15	60	°C
Storage Temp.	Tstg	-20	70	°C

MECHANICAL DATA

Item	Max.	Unit
Module Size (W X H X T)	67.0 X 27.5 X 8.5	mm
Viewing Area(W X H)	54.8 X 18.3	mm
Dot Pitch(W X H)	0.40 X 0.45	mm
Dot Size(W X H)	0.36 X 0.41	mm
View Angle	6 or 12 O'Clock	

ELECTRICAL CHARACTERISTICS (Vdd=5V±0.25V)

Item	Symbol	Test Condition	Min.	Typ.	Max.	Unit
Input High Voltage	Vih	--	2.0	--	Vdd	V
Input Low Voltage	Vil	--	-0.3	--	0.8	V
Output High Voltage	Voh	Ioh=-0.2mA	2.4	--	Vdd	V
Output Low Voltage	Vol	Iol=-1.6mA	0	--	0.4	V
Supply Current	Idd	Vdd=5.0V	--	0.6	1.0	mA
LCD Driving Voltage	Vdd - V0	Ta=25°C	--	4.7	--	V

PIN CONNECTIONS

Pin	Symbol	Level	Function
1	VDD	+5V	Power supply for logic
2	VSS	0V	Power GND
3	V0	--	Operation voltage for LCD
4	RST	L	Reset signal, active"L"
5	E1	H/L	Enable signal 1
6	E2	H/L	Enable signal 2
7	R/W	H/L	H:Read L:Write
8	A0	H/L	H:Data L:Instruction code
9	DB0	H/L	Data bus line
10	DB1	H/L	
11	DB2	H/L	
12	DB3	H/L	
13	DB4	H/L	
14	DB5	H/L	
15	DB6	H/L	
16	DB7	H/L	Power supply for LED backlight
17	BLA	+5V	
18	BLK	0V	

BLOCK DIAGRAM

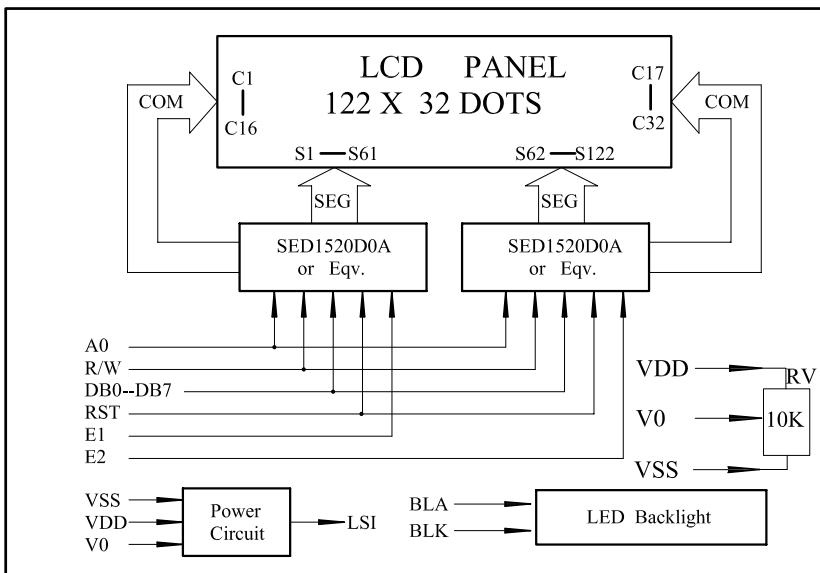

LCD Type

LCD Color	Backlight
Yellow Green	LED /4.1V (≤120mA)