

LCD&LCM SPECIFICATION

液晶显示屏产品使用说明书

MODULE NO.

128128C453A

128x128 图形点阵

COG 工艺

SPI 串口通讯

Designed	Checked	Approved

Revision history 修改记录

revision	date	description	remark
A00	2012-10-31	First release	
A01	2013-05-21		

Content/目录

1. **Feature/显示特性**
2. **Mechanical specifications/外形尺寸说明**
3. **Block diagram & power supply/电路原理图**
4. **Pin description/PIN 脚描述**
5. **Absolute maximum rating/限定参数**
6. **Electrical characteristics/电气特性**
7. **Backlight characteristics/背光特性**
8. **Electrical-optical characteristics/光学特性**
9. **Control and display commands/指令描述**
10. **DDRAM 映射表**
11. **Inspection standards/检验标准**
12. **Handling precautions/注意事项**

1. Feature/显示特性

- Display resolution/点阵数 : 128(w)*128(h)
- Display mode/显示模式 : FSTN ,Positive, Transflective (灰白膜, 正显, 半透明)
- Driving method/驱动方式 : 1/64 Duty , 1/9 Bias
- Viewing direction/视角 : 6:00 o'clock
- Backlight/背光 : LED , White(or Other)
- Built-in controller/控制器 : UC1617
- Operation temp/工作温度 : 0°C~50°C
- Storage temp/储存温度 : -10°C~60°C

2. Mechanical Specifications/外形尺寸说明

2.1 尺寸描述

- Dimensional outline (W*H*T)/外形尺寸 : 49.0mm*55.0mm*5.2mm
- Viewing area (W*H)/视域尺寸 : 42.0mm*44.5mm
- Active area(W*H)/显示尺寸 : 38.375mm*40.935mm
- Dot pitch (W*H)/点距 : 0.30mm*0.32mm
- Dot size (W*H)/点大小 : 0.275mm*0.295mm
- Weigh/重量 t : Approx

2.2 Outline Dimension 外形尺寸图

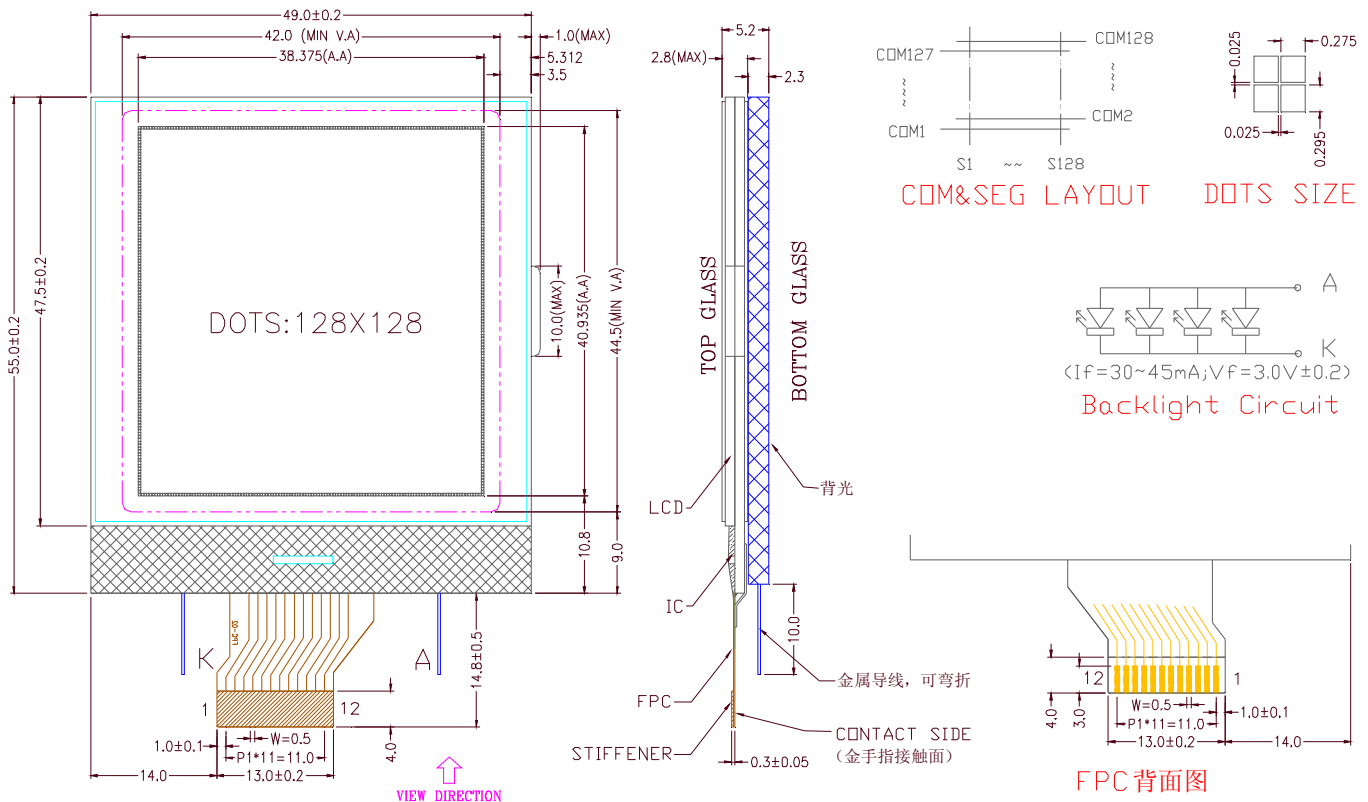

2. Block Diagram & Power supply/电路原理图

Hi-V GENERATOR REFERENCE CIRCUIT

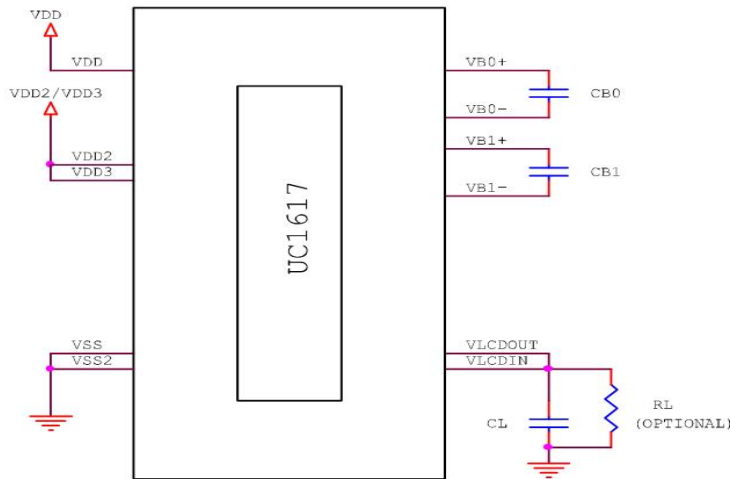

FIGURE 1: Reference circuit using internal Hi-V generator circuit

Note

- Sample component values: (The illustrated circuit and component values are for reference only. Please optimize for specific requirements of each application.)
 C_B : 150 ~ 250x LCD load capacitance or 2.2 μ F (5V), whichever is higher.
 C_L : 330 nF (25V) is appropriate for most applications.
 R_L : 3.3~10M Ω to act as a draining circuit when V_{DD} is shut down abruptly.

$R_L=NC$ (保留电阻位以便调节)

4. Pin description/PIN 脚描述

Pin No.	Pin Name	Function	
1	VLCD	Connect capacitors Ground	倍压输出
2	CB1+	Conntet capacitors between VB1+ and VB1-	接电容
3	CB1-		
4	CB0-	Conntet capacitors between VB0+ and VB0-	接电容
5	CB0+		
6	VDD	Power Supply. 3.0V	电源
7	VSS	GND. 0V	地
8	CD	Register select input, H: data; L: command	选择指令或数据
9	/CS	Chip select input pin.	片选
10	/RST	Reset signal (Low effective)	复位
11	SI (D3)	Serial data write and read input/output pin.	数据
12	SCL (D0)	Serial pixel clock signal input pin.	时钟
背光	A	LED正极, 工作电压3.0V, 工作电流30mA~45mA	
	K	LED负极, 0V	

5. Absolute Maximum Ratings/限定参数

Items	Symbol	MIN.	MAX.	Unit	Condition
Supply Voltage/供电电压	V _{DD}	-0.3	+3.0	V	V _{SS} = 0V
	V _{lcd}	-0.3	+13.0	V	V _{SS} = 0V
Input Voltage/输入电压	V _{IN}	-0.3	V _{DD} +0.3	V	V _{SS} = 0V
LED forward current/背光电流	I _f	0	30	mA	---
Operating Temp./工作温度	T _{OP}	0	+50	°C	---
Storage Temp./储存温度	T _{st}	-10	+60	°C	---

6. Electrical Characteristics/电气特性

6.1 Typical Electrical Characteristics

(V_{SS} = 0V, V_{DD} = 3.3V ± 10%, T_{OP} = 25°C)

ABSOLUTE MAXIMUM RATINGS

In accordance with IEC134, note 1 and 2.

Symbol	Parameter	Min.	Max.	Unit
V _{DD}	Logic Supply voltage	-0.3	+4.0	V
V _{DD2}	LCD Generator Supply voltage	-0.3	+4.0	V
V _{DD3}	Analog Circuit Supply voltage	-0.3	+4.0	V
V _{DD2/3} -V _{DD}	Voltage difference between V _{DD} and V _{DD2/3}	—	1.6	V
V _{LCD}	LCD Generated voltage (-30°C ~ +80°C)	-0.3	+19.8	V
V _{IN}	Digital input signal	-0.4	V _{DD} + 0.5	V
T _{OPR}	Operating temperature range	-30	+85	°C
T _{STR}	Storage temperature	-55	+125	°C

Notes

- V_{DD} is based on V_{SS} = 0V
- Stress beyond ranges listed above may cause permanent damages to the device.

SPECIFICATIONS

DC CHARACTERISTICS

Symbol	Parameter	Conditions	Min.	Typ.	Max.	Unit
V _{DD}	Supply for digital circuit		1.65		3.45	V
V _{DD2/3}	Supply for bias & pump		2.5		3.45	V
V _{LCD}	Charge pump output	V _{DD2/3} ≥ 2.6V, 25°C		14	15	V
V _D	LCD data voltage	V _{DD2/3} ≥ 2.6V, 25°C	0.89		1.78	V
V _{IL}	Input logic LOW				0.2V _{DD}	V
V _{IH}	Input logic HIGH		0.8V _{DD}			V
V _{OL}	Output logic LOW				0.2V _{DD}	V
V _{OH}	Output logic HIGH		0.8V _{DD}			V
I _{IL}	Input leakage current				1.5	μA
I _{SB}	Standby current	V _{DD} = V _{DD2/3} = 3.3V, Temp = 85°C			50	μA
C _{IN}	Input capacitance			5	10	pF
C _{OUT}	Output capacitance			5	10	pF
R _{ON(SEG)}	SEG output impedance	V _{LCD} = 15V		1.5	2.0	kΩ
R _{ON(COM)}	COM output impedance	V _{LCD} = 15V		1.5	2.0	kΩ
f _{LINE}	Average Line rate	LC[4:3] = 10b	-10%	21.1	+10%	kHz

POWER CONSUMPTION

$V_{DD} = 2.7V$,
 $V_{LCD} = 14V$,
Mux Rate = 128,
 $C_B = 2.2\mu F$,
All HV outputs are open circuit.

Bias Ratio = 11,
Line Rate = 10b,
Bus mode = 6800,
Temperature = 25°C,

PM = 78,
Panel Loading (PC[1:0]) = 10b,
 $C_L = 330nF$,
OTP=00H,

Display Pattern	Conditions	Typ. (μA)	Max. (μA)
All-OFF	Bus = idle	576	806
2-pixel checker	Bus = idle	704	986
-	Bus = idle (standby current)	-	5

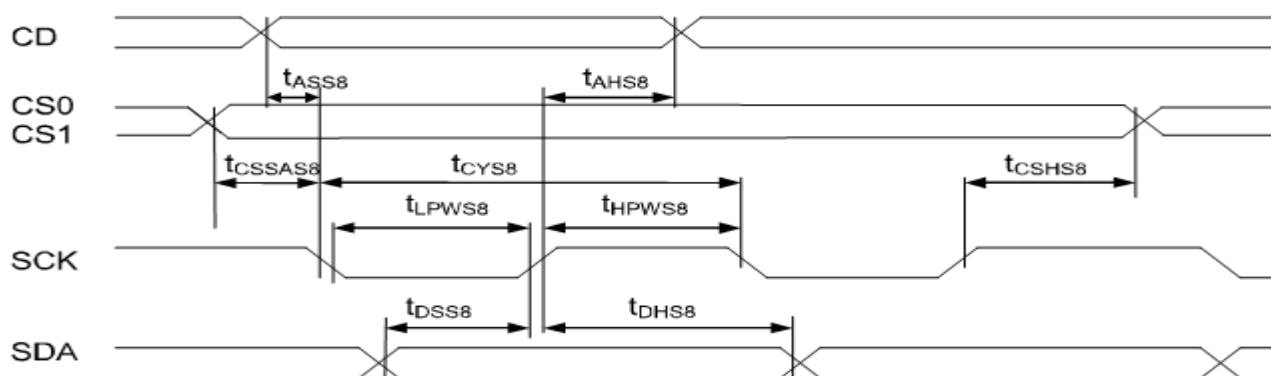
6.2 Timing Specifications**FIGURE 15: Serial Bus Timing Characteristics (for S8 / S8uc)**

($2.5V \leq V_{DD} < 3.3V$, $T_a = -30$ to $+85^\circ C$)

Symbol	Signal	Description	Condition	Min.	Max.	Units
t_{ASS8}	CD	Address setup time		0	—	nS
t_{AHS8}		Address hold time		0	—	nS
t_{CYS8}	SCK	System cycle time		40	—	nS
t_{LPWS8}		Low pulse width		20	—	nS
t_{HPWS8}		High pulse width		20	—	nS
t_{DSS8}	SDA	Data setup time		15	—	nS
t_{DHS8}		Data disable time		0	—	nS
t_{CSSAS8}	CS1/CS0	Chip select setup time		5	—	nS
t_{CSHS8}		Chip select hold time		5	—	nS

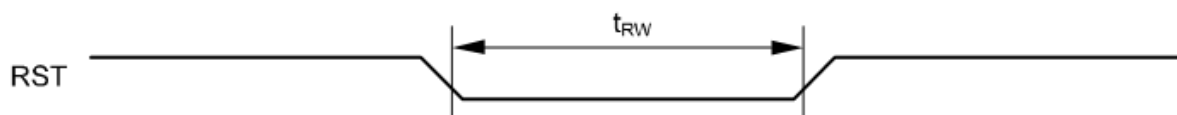
Reset timing**FIGURE 17: Reset Characteristics**

($1.65V \leq V_{DD} < 3.3V$, $T_a = -30$ to $+85^\circ C$)

Symbol	Signal	Description	Condition	Min.	Max.	Units
t_{RW}	RST	Reset low pulse width		3	—	μS
t_{RD}	RST, WR	Reset to WR pulse delay		10	—	mS

7. Backlight Characteristics/背光特性

Items	Symbol	MIN.	TYP.	MAX.	Unit	Condition
Forward Voltage/电压	Vf	2.8	3.0	3.1	V	If=30mA
Reverse current/电流	Ir	---	30	45	mA	Vr=3V
Peak wave length/波长	λ	---	---	---	nM	If=30mA
Luminance/亮度	Lv	---	---	---	Cd/m ²	If=30mA
Color /颜色	White (白色, 或者其他色)					

8. Electrical-Optical Characteristics/光学特性

Items	Symbol	Condition	MIN.	TYP.	MAX.	Unit	NOTE
Response time/反应时间	Tr	Ta= 25°C	---	250	---	ms	2
	Tf		---	400	---		
Contrast ratio/对比度	Cr	Ta= 25°C	---	--	---	degree	3
Viewing angle range/视角范围	θ	Cr \geq 2	-40	---	40		

Note 1. Definition of response time

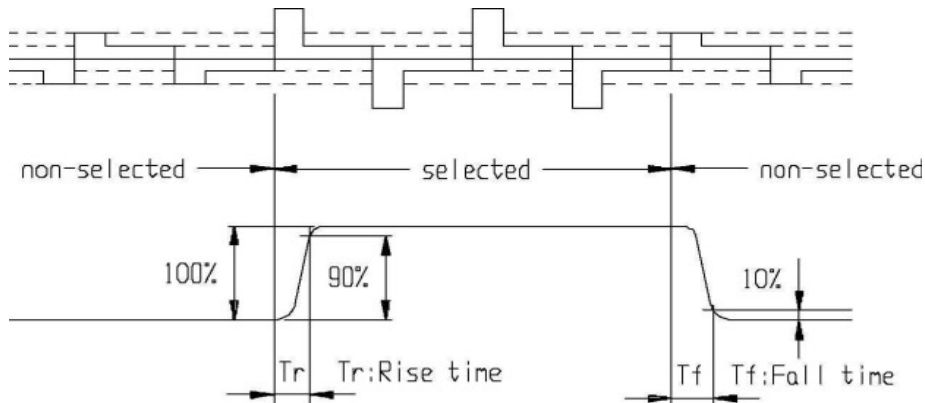

Note2 . Definition of Contrast Ratio 'Cr'

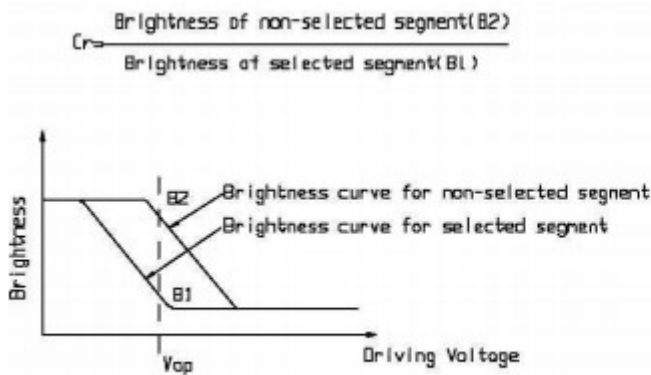

Note 3. Definition of Viewing Angle Range 'θ'

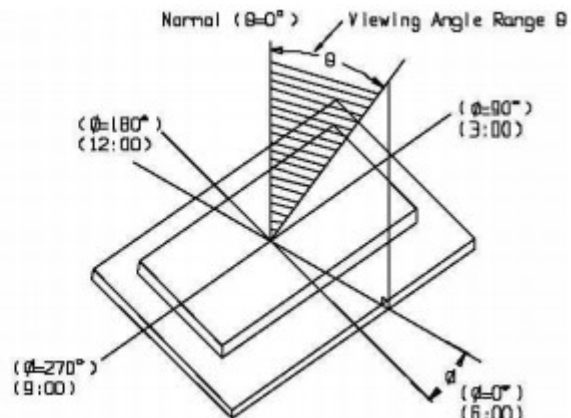

9. Control and display commands/指令描述

COMMAND SUMMARY

The following is a list of host commands supported by UC1617

C/D: 0: Control, 1: Data
 W/R: 0: Write Cycle, 1: Read Cycle
 # Useful Data bits
 - Don't Care

	Command	C/D	W/R	D7	D6	D5	D4	D3	D2	D1	D0	Action	Default	
1	Write Data Byte	1	0	#	#	#	#	#	#	#	#	Write 1 byte	N/A	
2	Read Data Byte	1	1	#	#	#	#	#	#	#	#	Read 1 byte	N/A	
3	Get Status	0	1	1	MX	MY	WA	DE	WS	MD	MS	Get {Status, Ver, PMO, Product Code, PID, MID}	N/A	
				Ver		PMO[5:0]								
				Product Code			PID		MID					
4	Set Page_C Address	0	0	0	0	0	#	#	#	#	#	Set CA[4:0]	0H	
5	Set Temp. Compensation	0	0	0	0	1	0	0	1	#	#	Set TC[1:0]	00b	
6	Set Panel Loading	0	0	0	0	1	0	1	0	#	#	Set PC[1:0]	10b	
7	Set Pump Control	0	0	0	0	1	0	1	1	#	#	Set PC[3:2]	11b	
8	Set Adv. Program Control (double-byte command)	0	0	0	0	1	1	0	0	R	R	Set APC[R][7:0], R = 0, 1 or 2	N/A	
		0	0	#	#	#	#	#	#	#	#			
9	Set Scroll Line LSB	0	0	0	1	0	0	#	#	#	#	Set SL[3:0]	0H	
	Set Scroll Line MSB	0	0	0	1	0	1	-	#	#	#	Set SL[6:4]	0H	
10	Set Row Address LSB	0	0	0	1	1	0	#	#	#	#	Set RA[3:0]	00H	
	Set Row Address MSB	0	0	0	1	1	1	-	#	#	#	Set RA[6:4]	00H	
11	Set V _{BIAS} Potentiometer (double-byte command)	0	0	1	0	0	0	0	0	0	1	Set PM[7:0]	4EH	
		0	0	#	#	#	#	#	#	#	#			
12	Set Partial Display Control	0	0	1	0	0	0	0	1	#	#	Set LC[9:8]	00b: Disable	
13	Set RAM Address Control	0	0	1	0	0	0	1	#	#	#	Set AC[2:0]	001b	
14	Set Fixed Lines	0	0	1	0	0	1	0	0	0	0	Set {FLT, FLB}	0	
15	Set Line Rate	0	0	1	0	1	0	0	0	#	#	Set LC[4:3]	00b	
16	Set All-Pixel-ON	0	0	1	0	1	0	0	1	0	#	Set DC[1]	0b	
17	Set Inverse Display	0	0	1	0	1	0	0	1	1	#	Set DC[0]	0b	
18	Set Display Enable	0	0	1	0	1	0	1	1	#	#	Set DC[3:2]	10b	
19	Set LCD Mapping Control	0	0	1	1	0	0	0	#	#	#	Set LC[2:0]	000b	
20	Set N-Line Inversion	0	0	1	1	0	0	1	0	0	0	Set NIV[3:0]	6H	
				-	-	-	-	#	#	#	#			
21	Set LCD Gray Shade	0	0	1	1	0	1	0	#	#	#	Set LC[7:5]	001b	
22	System Reset	0	0	1	1	1	0	0	0	1	0	System Reset	N/A	
23	NOP	0	0	1	1	1	0	0	0	1	1	No operation	N/A	
24	Set Test Control (double-byte command)	0	0	1	1	1	0	0	1	TT		For testing only. Do not use.	N/A	
		0	0	#	#	#	#	#	#	#	#			
25	Set LCD Bias Ratio	0	0	1	1	1	0	1	0	#	#	Set BR[1:0]	11b: 11	
26	Reset Cursor Update Mode	0	0	1	1	1	0	1	1	1	0	AC[3]=0, CA=CR	AC[3]=0	
27	Set Cursor Update Mode	0	0	1	1	1	0	1	1	1	1	AC[3]=1, CR=CA	AC[3]=1	
28	Set COM End	0	0	1	1	1	1	0	0	0	1	Set CEN[6:0]	127	
		0	0	-	#	#	#	#	#	#	#			
29	Set Partial Display Start	0	0	1	1	1	1	0	0	1	0	Set DST[6:0]	0	
		0	0	-	#	#	#	#	#	#	#			
30	Set Partial Display End	0	0	1	1	1	1	0	0	1	1	Set DEN[6:0]	127	
		0	0	-	#	#	#	#	#	#	#			

	Command	C/D	W/R	D7	D6	D5	D4	D3	D2	D1	D0	Action	Default	
31	Set Window Program Starting Page_C Address	0 0	0 0	1 -	1 -	1 -	1 #	0 #	1 #	0 #	0 #	Shared with MTP commands	Set WPC0	0
32	Set Window Programming Starting Row Address	0 0	0 0	1 -	1 #	1 #	1 #	0 #	1 #	0 #	1 #		Set WPP0	0
33	Set Window Programming Ending Page_C Address	0 0	0 0	1 -	1 -	1 -	1 #	0 #	1 #	1 #	0 #		Set WPC1	31
34	Set Window Programming Ending Row Address	0 0	0 0	1 -	1 #	1 #	1 #	0 #	1 #	1 #	1 #		Set WPP1	127
35	Enable window program	0	0	1	1	1	1	1	0	0	#	Set AC[4]	0: Disable	
36	Set MTP Operation control	0 0	0 0	1 -	0 -	1 #	1 #	1 #	0 #	0 #	0 #	Set MTPC[5:0]	10H	
37	Set MTP Write Mask	0 0	0 0	1 #	0 #	1 #	1 #	1 #	0 #	0 #	1 #	Set MTPM[7:0]	0	
38	Set V _{MTP1} Potentiometer	0 0	0 0	1 #	1 #	1 #	1 #	0 #	1 #	0 #	0 #	Shared with Window Program commands	Set MTP1	N/A
39	Set V _{MTP2} Potentiometer	0 0	0 0	1 #	1 #	1 #	1 #	0 #	1 #	0 #	1 #		Set MTP2	
40	Set MTP Write Timer	0 0	0 0	1 #	1 #	1 #	1 #	0 #	1 #	1 #	0 #		Set MTP3	
41	Set MTP Read Timer	0 0	0 0	1 #	1 #	1 #	1 #	0 #	1 #	1 #	1 #		Set MTP4	

Notes:

- Any bit patterns other than the commands listed above may result in undefined behavior.
- The interpretation of commands (37)~(41) depends on register MTPC[3].
- Commands (38)~(41) are shared with commands (31)~(34) and have exactly the same code. When MTPC[3]=0, commands (38)~(41) are interpreted as Window Programming commands. When MTPC[3]=1, they are the MTP Control commands.
- MTPM and PM are actually the same register. Only one of the commands (37 or 11) is valid at any time, and it is determined by MTPC[3].
- After MTP-ERASE or MTP-PROGRAM operation, before resuming normal operation, please always
 - Remove TST4 power source,
 - Do a full V_{DD} ON-OFF-ON cycle.

10. DDRAM 映射表

128128C453A

Line Addresss	Data									Data				
	D1/0	D3/2	D5/4	D7/6	D1/0	D3/2	D5/4	D7/6		D1/0	D3/2	D5/4	D7/6	
00H														
01H														
02H														
03H														
04H														
05H														
06H														
07H														
08H														
09H														
0AH														
0BH														
0CH														
0DH														
0EH														
0FH														
10H														
11H														
12H														
13H														
14H														
15H														
16H														
17H														
18H														
19H														
1AH														
1BH														
	Page_C0				Page_C1				Page_C31					
6CH														
6DH														
6EH														
6FH														
70H														
71H														
72H														
73H														
74H														
75H														
76H														
77H														
78H														
79H														
7AH														
7BH														
7CH														
7DH														
7EH														
7FH														
MX														
	0	C1	C2	C3	C4	C5	C6	C7	C8		C125	C126	C127	C128
	1	C128	C127	C126	C125	C124	C123	C122	C121		C4	C3	C2	C1

MY=0		MY=1	
SL=0	SL=16	SL=0	SL=16
R1	R113	R128	R16
R2	R114	R127	R15
R3	R115	R126	R14
R4	R116	R125	R13
R5	R117	R124	R12
R6	R118	R123	R11
R7	R119	R122	R10
R8	R120	R121	R9
R9	R121	R120	R8
R10	R122	R119	R7
R11	R123	R118	R6
R12	R124	R117	R5
R13	R125	R116	R4
R14	R126	R115	R3
R15	R127	R114	R2
R16	R128	R113	R1
R17	R1	R112	R128
R18	R2	R111	R127
R19	R3	R110	R126
R20	R4	R109	R125
R21	R5	R108	R124
R22	R6	R107	R123
R23	R7	R106	R122
R24	R8	R105	R121
R25	R9	R104	R120
R26	R10	R103	R119
R27	R11	R102	R118
R28	R12	R101	R117
R109	R93	R20	R36
R110	R94	R19	R35
R111	R95	R18	R34
R112	R96	R17	R33
R113	R97	R16	R32
R114	R98	R15	R31
R115	R99	R14	R30
R116	R100	R13	R29
R117	R101	R12	R28
R118	R102	R11	R27
R119	R103	R10	R26
R120	R104	R9	R25
R121	R105	R8	R24
R122	R106	R7	R23
R123	R107	R6	R22
R124	R108	R5	R21
R125	R109	R4	R20
R126	R110	R3	R19
R127	R111	R2	R18
R128	R112	R1	R17

128	128
MUX	

Example: when MX=0, MY=0, SL=0, the corresponding data in SRAM as the pixels shown is:

Row1 Page_C0 ⇨ 11100100b

Row2 Page_C0 ⇨ 10010011b

12. Inspection Standards/检验标准

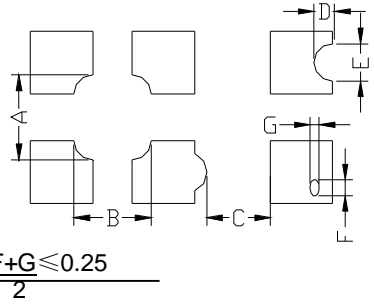
Item	Criterion for defects	Defect type
1) Display on inspection/显示效果	(1) Non display (2) Vertical line is deficient (3) Horizontal line is deficient (4) Cross line is deficient	Major
2) Black / White spot/黑点或白点	Size Φ (mm) Acceptable number $\Phi \leq 0.3$ Ignore (note) $0.3 < \Phi \leq 0.45$ 3 $0.45 < \Phi \leq 0.6$ 1 $0.6 < \Phi$ 0	Minor
3) Black / White line/黑线或白线	Length (mm) Width (mm) Acceptable number $L \leq 10$ $W \leq 0.03$ Ignore $5.0 \leq L \leq 10$ $0.03 < W \leq 0.04$ 3 $5.0 \leq L \leq 10$ $0.04 < W \leq 0.05$ 2 $1.0 \leq L \leq 10$ $0.05 < W \leq 0.06$ 2 $1.0 \leq L \leq 10$ $0.06 < W \leq 0.08$ 1 $L \leq 10$ $0.08 < W$ follows 2) point defect Defects separate with each other at an interval of more than 20mm	Minor
4) Display pattern/显示模式	 <p style="text-align: center;"> $\frac{A+B \leq 0.28}{2}$ $0 < C$ $\frac{D+E \leq 0.25}{2}$ $\frac{F+G \leq 0.25}{2}$ </p> <p>Note: 1) Up to 3 damages acceptable 2) Not allowed if there are two or more pinholes every three-fourth inch.</p>	Minor
5) Spot-like contrast irregularity/均匀度	Size Φ (mm) Acceptable Number $\Phi \leq 0.7$ Ignore (note) $0.7 < \Phi \leq 1.0$ 3 $1.0 < \Phi \leq 1.5$ 1 $1.5 < \Phi$ 0 Note: 1) Conformed to limit samples. 2) Intervals of defects are more than 30mm.	Minor
6) Bubbles in polarizer/玻璃内有气泡	Size Φ (mm) Acceptable Number $\Phi \leq 0.4$ Ignore (note) $0.4 < \Phi \leq 0.65$ 2 $0.65 < \Phi \leq 1.2$ 1 $1.2 < \Phi$ 0	Minor
7) Scratches and dent on the polarizer/玻璃刮痕/凹痕	Scratches and dent on the polarizer shall be in the accordance with "2) Black/white spot", and "3) Black/White line".	Minor
8) Stains on the surface of LCD panel/玻璃上有污点	Stains which cannot be removed even when wiped lightly with a soft cloth or similar cleaning.	Minor
9) Rainbow color/杂色	No rainbow color is allowed in the optimum contrast on state within the active area.	Minor
10) Viewing-area encroachment/玻璃边线出现在视域	Polarizer edge or line is visible in the opening viewing area due to polarizer shortness or sealing line.	Minor
11) Bezel appearance/铁筐外观	Rust and deep damages that are visible in the bezel are rejected.	Minor
12) Defect of land surface 表面缺陷	Evident crevices that are visible are rejected.	Minor
13) Parts mounting/部件安装	(1) Failure to mount parts (2) Parts not in the specifications are mounted (3) For example: Polarity is reversed, HSC or TCP falls off.	Minor
14) Part alignment/部件结合度	(1) LSI, IC lead width is more than 50% beyond pad outline. (2) More than 50% of LSI, IC leads is off the pad outline.	Minor
15) Conductive foreign matter (solder ball, solder hips)/杂质 (焊接遗留物)	(1) $0.45 < \Phi$, $N \geq 1$ (2) $0.3 < \Phi \leq 0.45$, $N \geq 1$, Φ : Average diameter of solder ball (unit: mm) (3) $0.5 < L$, $N \geq 1$, L: Average length of solder chip (unit: mm)	Minor
16) Bezel flaw/铁筐破裂	Bezel claw missing or not bent	Minor
17) Indication on name plate (sampling indication label)/标志	(1) Failure to stamp or label error, or not legible.(all acceptable if legible) (2) The separation is more than 1/3 for indication discoloration, in which the characters can be checked.	Minor

12. Handling precautions 注意事项

1. Refrain from strong mechanical shock and forces to the module. It may cause improper operating or damage to the module.
防止震动和压迫模组，以免造成模组损坏和运行正常。
2. The polarizer used on the display surface is easily scratched and damaged. Extreme care should be taken when handling. When cleaning the display surface, use soft cloth with a solvent recommended : ethyl alcohol , isopropyl or hexane) and wipe gently, do not use the following solvents : water, ketone or aromatics .
模组表面的偏光极易被刮伤和损坏，所以操作是要非常小心。请用蘸有乙醇，丙酮等溶剂的湿软布轻轻擦拭，不要使用水，乙酮等溶剂。
3. Wipe off water or oil drop immediately If you leave drop for a long time, stain and discoloration may occur.
要立即擦拭掉屏幕上的油滴和水滴，否则会出现污点和杂质。
4. Do not touch pads or pins of interface directly with bare hands. When handling the LCD module, put on a soft glover like finger-glover.
不要直接用手去触碰接口处的金属管脚。当操作模组的时候，请配带软指套。
5. Protect the module from static electricity, it may cause damage to CMOS LSI.
模组需要有防静电保护，否则会损坏CMOS LSI。
6. To prevent LCD panels from degradation, do not operate or store them exposed directly to sunlight or high temperature/humidity.
不要直接在太阳,高温或潮湿环境下操作和储存LCD模组，以免影响模组的质量。
7. If the liquid crystal leaks from the panel it should be kept away from the eyes and mouths. In case of contact with skins, wash away thoroughly with soap and water.
若有液晶漏出，务必避免其入眼入口。若沾到皮肤上了，马上用肥皂和水冲洗干净。
8. Soldering should be only performed on the I/O terminals within the temperature of $280 \pm 20^{\circ}\text{C}$ and soldering time should be less than 4 seconds.
要在 $280 \pm 20^{\circ}\text{C}$ 的条件下在I/O终端实现焊接，并且保证焊接时间短于4秒。
9. Supply voltage within the specified voltage limit, the maximum rating, higher voltage cause the shorter LCD life or damaged.
绝对要在指定的电压范围内驱动模组， 因为如果在高于指定电压的情况下驱动模组，会使模组寿命变短
10. Do not input any signals before power is turned on. Do not connect or disconnect the module on the state of Power-ON.
供电之前不要输入任何信号，不要在通电时连接和段开 LCD 模组。