

G12232-2B	122 DOTS×32 DOTS	1/32 DUTY	1/6 BIAS
------------------	-------------------------	------------------	-----------------

FEATURE:

LCD TYPE	STN/FSTN
LCM BACKLIGHT TYPE	LED BACKLIGHT
LCM CONTROLLER IC	BUILT IN SED1520 OR EQUIVALENT
POWER SUPPLY FOR LCM	DC +3.3V
LED BACKLIGHT INPUT	DC +3.3V
EL BACKLIGHT INPUT	----
EL INVERTER	----
FL BACKLIGHT INPUT	-
FL INVERTER	-
LCM DIMENSION	84.0×44.0×9.5 mm
LCM VIEWING AREA	60.0×18.0 mm
LCD DOT SIZE	0.40×0.45 mm
LCD DOT PITCH	0.44×0.49 mm

3.ABSOLUTE MAXIMUM RATINGS:

ITEM	SYM	MIN	TYP	MAX	UNIT
OPERATING TEMP.	Top	-20	-	+70	
STORAGE TEMP.	Tst	-30	-	+80	
INPUT VOLTAGE	Vi	Vss	-	VDD	V
SUPPLY VOL. FOR LOGIC	VDD-Vss	-	3.3	6.6	V
SUPPLY VOL. FOR LCD	VDD-Vo	-	-	6.5	V

5.INTERFACE PIN CONNECTIONS:

NO	SYM	LEVEL	FUNCTION
1	Vss	-	0V
2	VDD	-	+3.3V
3	Vo	-	CONTRAST ADJ.
4	Ao	H/L	H:DATA, L:INSTRUCTION CODE
5	NC	---	----
6	E2	H,H→L	Chip select for IC2
7	NC	---	----
8	E1	H,H→L	Chip select for IC1
9	R/W	H/L	H:READ(LCM →MPU) L:WRITE(MPU→LCM)
10	DB0	H/L	DATA BIT0
11	DB1	H/L	DATA BIT1
12	DB2	H/L	DATA BIT2
13	DB3	H/L	DATA BIT3
14	DB4	H/L	DATA BIT4
15	DB5	H/L	DATA BIT5
16	DB6	H/L	DATA BIT6
17	DB7	H/L	DATA BIT7
18	RES	H/L	RESET SIGNAL
19	A(+)	+3.3V	BACKLIGHT(+)
20	K(-)	0V	BACKLIGHT(-)

2.ELECTRICAL CHARACTERISTICS:

ITEM	SYM	CONDITION	MIN	TYP	MAX	UNIT
SUPPLY VOLTAGE FOR LOGIC	VDD-Vss	Ta = 2 5	-	3.3	5.0	V
SUPPLY VOLTAGE FOR LCD DRIVER	VDD-Vss	Ta = 2 5	-	-	-	V
OPERATING VOL. FOR LCD MODULE	VDD-Vo	Ta = 2 5	-	2.8	-	V
INPUT HIGH VOL.	VIH	-	2.2	-	VDD	V
INPUT LOW VOL.	VIL	-	0	-	0.6	V
SUPPLY CURRENT FOR LOGIC	IDD	VDD=5.0V	-	3.0	4.5	mA
SUPPLY CURRENT FOR LCD	ILCD	-	-	-	6.0	mA
LED CURRENT	IF	Ta = 2 5	-	60	-	mA
LED DISSIPATION	PD	Ta = 2 5	-	300	-	mW

4. BLOCK DIAGRAM:

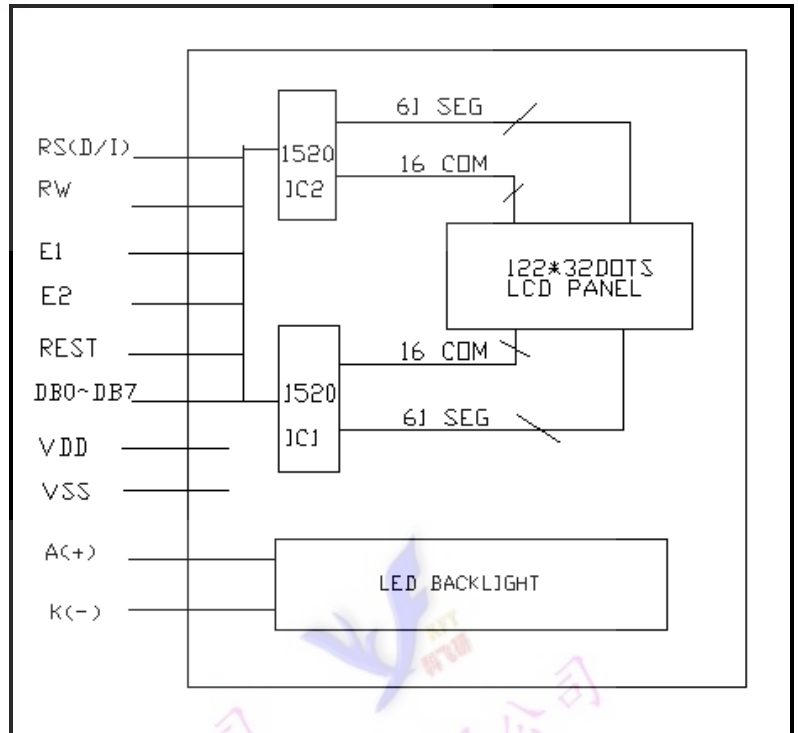

6.DIMENSIONAL DRAWING :

