

SPECIFICATION FOR APPROVAL

Product Type: Graphic Type STN Dot Matrix
LCD Modul

Part NO.: G240128A

Customer: _____

Customer Part No.: _____

Date: _____

APPOVED SIGNATURES

BLUE MOON	Customer

目 录

(一) 显示特性	(1)
(二) 机械特性	(1)
(三) 模块图	(2)
(四) 限定参数	(2)
(五) 电气特性及使用说明	(2)
(六) 光学特性	(5)
(七) 可靠性	(8)
(八) 注意事项	(9)



1 Display Specification

1.1 Display type: STN

1.2 Display color

Display color: Blue-Black

Background color: Yellow-Green

1.3 Polarizer mode: Positive

Reflective

1.4 Viewing Angle: 6:00

1.5 Driving Duty: 1/128

1.6 Backlight: LED

- Color tone is slightly changed by temperature and driving voltage.

2 Mechanical Specifications

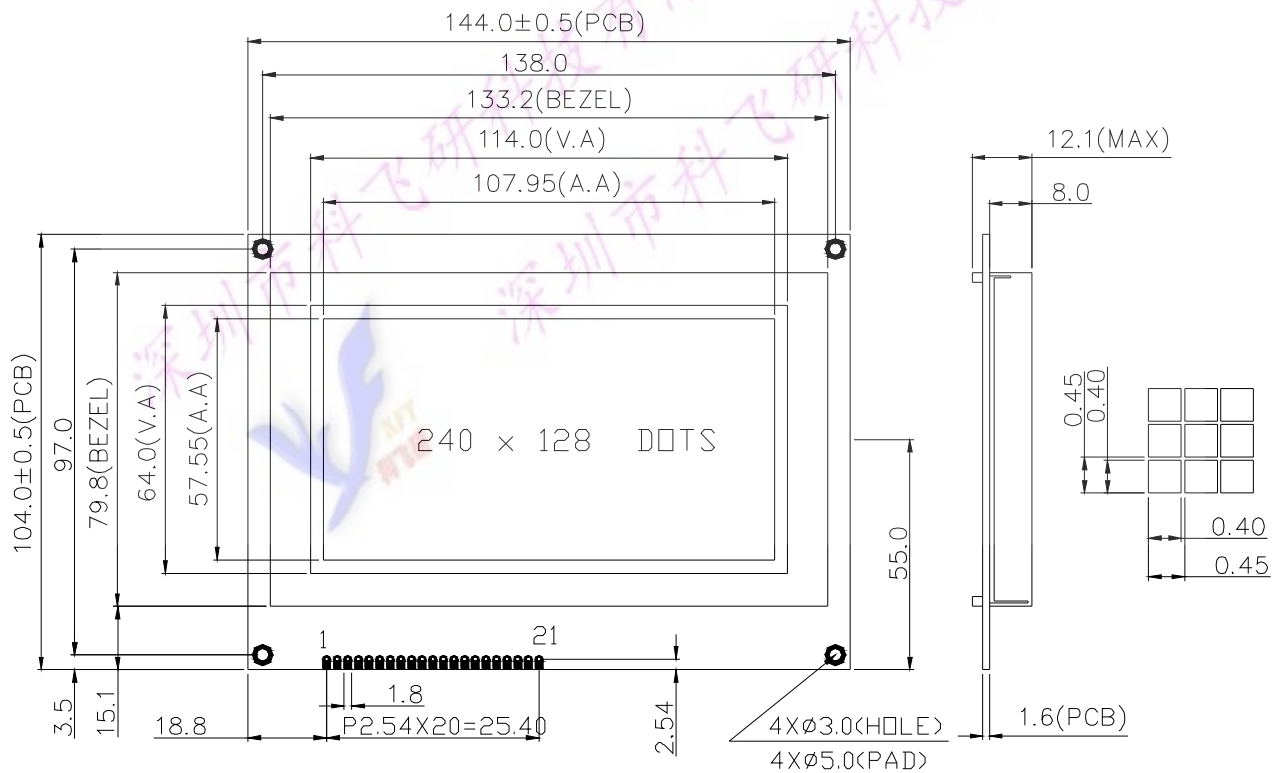

2.1 Outline Dimensions

2.2 Dot Matrix: 240×128

2.3 Dot size: 0.40×0.40(mm)

2.4 Dot pitch: 0.45×0.45(mm)

3 Circuit Block Diagram

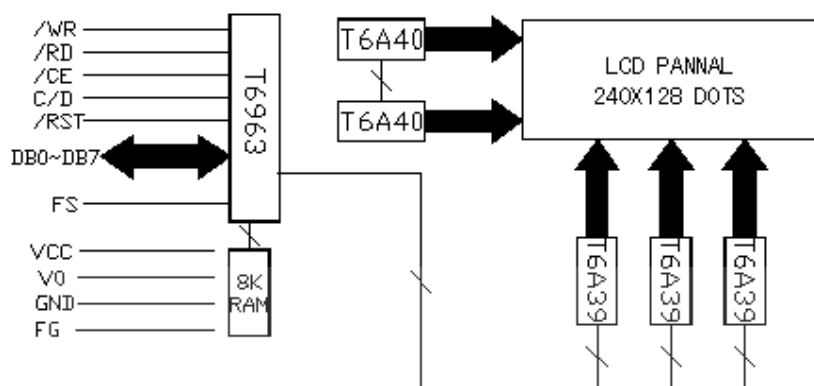

4 Absolute Maximum Ratings

Item	Symbol	Min.	Max.	Unit	Remark
Power Supply Voltage	VDD-VSS	0	7.0	V	
LCD Driving Voltage	VDD-VEE	---	18.0		
Operating Temperature Range	Top	-20	70	°C	NO Condensation
Storage Temperature Range	Tst	-30	80		

5 Electrical Specifications and Instruction Code

5.1 Electrical Characteristics

Item	Symbol	Min.	Typ.	Max.	Unit	Remark
Supply Voltage(logic)	VDD-VSS	4.5	5.0	5.5	V	
Supply Voltage(LCD Drive)	VSS-VEE	---	6.0	---	V	
Input Signal Voltage	“H” Level	VIN	VDD-2.2	---	VDD	V
	“L” Level	VIL	0	---	0.8	V
Supply current(logic)	IDD	---	24	---	mA	
Supply current (LCD Drive)	IEE	---	2.0	---	mA	

5.2 Interface Signals

J1 接口

Pin NO.	Symbol	Description(Function)	Remark
1	FG	Module Frame Ground	
2	VSS	Ground	
3	VDD	Supply voltage for logic and LCD(+)	
4	V0	Operating voltage for LCD	variable
5	WR	Data Write into T6963C	
6	RD	Data Read F from T6963C	
7	CE	Chip enable Signal	
8	C/D	Command/Data Selection	
9	Reset	Reset signal	
10	DB0	Data bit 0	
11	DB1	Data bit 1	
12	DB2	Data bit 2	
13	DB3	Data bit 3	
14	DB4	Data bit 4	
15	DB5	Data bit 5	
16	DB6	Data bit 6	
17	DB7	Data bit 7	
18	FS	Font Selection	
19	VEE	LCD 驱动负压	
20	LED(+)	LED or EL Backlight	
21	LED(-)	LED or EL Backlight	

J2和J3接口与J1接口从1脚开始一一对应

5.3 Interface Timing Chart:

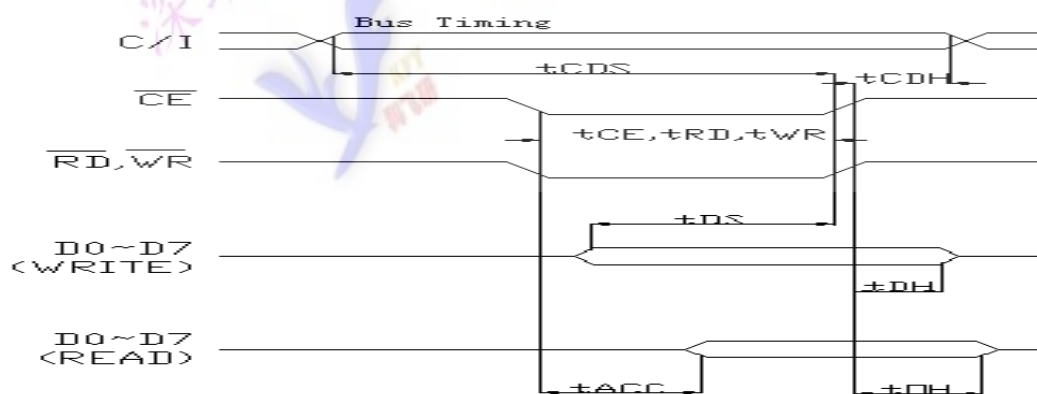

Unless otherwise specified, VDD=5.0±10%, VSS=0V, Ta=-10~70°C

Item	Symbol	Test Condition	MIN	MAX	UNIT
C/D Set up Time	t_{CDS}		100	--	ns
C/D Hold Time	t_{CDH}		10	--	ns
CE, RD, WR Width	t_{CE}, t_{RD}, t_{WR}		80	--	ns
Data Set up Time	t_{DS}		80	--	ns
Data Hold Time	t_{DH}		40	--	ns
Access Time	t_{ACC}		--	150	ns
Output Hold Time	t_{OH}		10	50	ns

5.4 Instruction Code

<i>COMMAND</i>	<i>CODE</i>	<i>D1</i>	<i>D2</i>	<i>FUNCTION</i>
REGISTERS	00100001	X address	Y address	Set Cursor Pointer
	00100010	Data	00H	Set Offset Register
	SETTING 00100100	Low address	High address	Set Address Pointer
SET CONONTROL WORD	01000000	Low address	High address	Set Text Home Address
	01000001	Columns	00H	Set Text Area
	01000010	Low address	High address	Set Graphic Home Address
	01000011	Columns	00H	Set Graphic Area
MODE SET	1000x000	--	--	OR mode
	1000x001	--	--	EXOR mode
	1000x011	--	--	AND mode
	1000x100	--	--	Text Attribute mode
	10000xxx	--	--	Internal CG ROM mode
	10001xxx	--	--	External CG RAM mode
DISPLAY MODE	10010000	--	--	Display off
	1001xx10	--	--	Cursor on, blink off
	1001xx11	--	--	Cursor on, blink on
	100101xx	--	--	Text on, graphic off
	100110xx	--	--	Text off, graphic on
	100111xx	--	--	Text on, graphic on
CURSOR PATTERN ELECT	10100000	--	--	1-line cursor
	10100001	--	--	2-line cursor
	10100010	--	--	3-line cursor
	10100011	--	--	4-line cursor
	10100100	--	--	5-line cursor
	10100101	--	--	6-line cursor
	10100110	--	--	7-line cursor
	10100111	--	--	8-line cursor
DATA AUTO	10110000	--	--	Set Data Auto Write
READ/WRITE	10110001	--	--	Set Data Auto Read
	10110010	--	--	Auto Reset
DATA READ/WRITE	11000000	--	--	Data Write and Increment
	11000001	--	--	Data Read and Increment
	11000010	--	--	Data Write and Decrement
	11000011	--	--	Data Read and Decrement
	11000100	--	--	Data Write and Non variable
	11000101	--	--	Data Read and Non variable
SCREEN PEEK	11100000	--	--	Screen Peek
SCREEN COPY	11101000	--	--	Screen Copy
BIT SET/RESET	11110xxx	--	--	Bit reset
	11111xxx	--	--	Bit set
	1111x000	--	--	Bit0(LSB)
	1111x001	--	--	Bit1
	1111x010	--	--	Bit2
	1111x011	--	--	Bit3
	1111x100	--	--	Bit4
	1111x101	--	--	Bit5
	1111x110	--	--	Bit6
	1111x111	--	--	Bit7(MSB)

5.5 Character Code Map

LSB MSB	0	1	2	3	4	5	6	7	8	9	A	B	C	D	E	F
0	!	"	#	\$	%	&	'	()	*	+	,	-	.	/	
1	0	1	2	3	4	5	6	7	8	9	:	;	<	=	>	?
2	0	A	B	C	D	E	F	G	H	I	J	K	L	M	N	O
3	P	Q	R	S	T	U	U	U	X	Y	Z	[\]	^	_
4	'	a	b	c	d	e	f	g	h	i	j	k	l	m	n	o
5	P	q	r	s	t	u	u	u	w	x	y	z	{		}	~
6	S	u	é	à	á	â	ã	ä	å	æ	è	é	ê	ë	ì	í
7	E	æ	È	é	ê	ë	ü	ü	ü	9	0	0	0	C	E	半

6 Optical Characteristics

6.1 Optical Characteristics Ta=25°C

Item	Symbol	Condition	Min.	Typ.	Max.	Unit	Remark
Viewing angle	θ_x	Cr $\theta_y=0$	-20	----	20	deg	
	θ_y	>3 $\theta_x=0$	-25	----	-25		
Contrast Ratio	Cr	$\theta_x=0^\circ$ $\theta_y=15^\circ$	3				
Response Time	Turn on	Ton	$\theta_x=0^\circ$		200	ms	
	Turn off	Toff	$\theta_y=0^\circ$		360		

6.2 Definition of optical characteristics

6.2.1 Definition of viewing Angle(see fig.as follow)

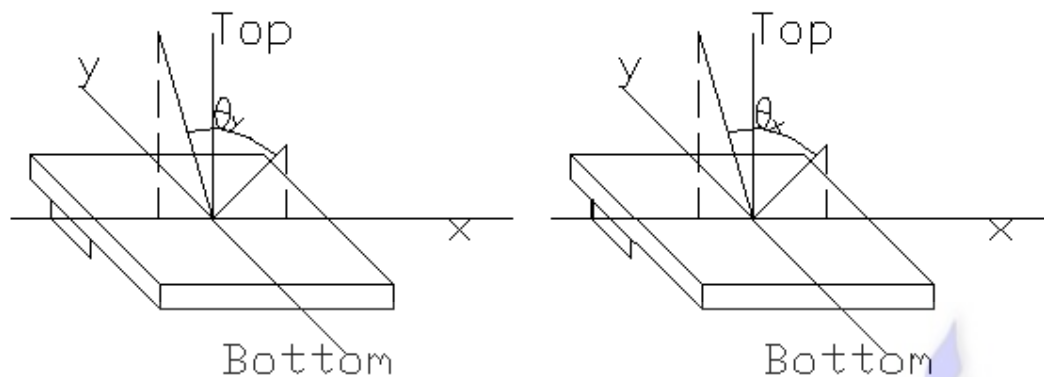

6.2.2 Definition of Contrast Ratio (see fig. as follow)

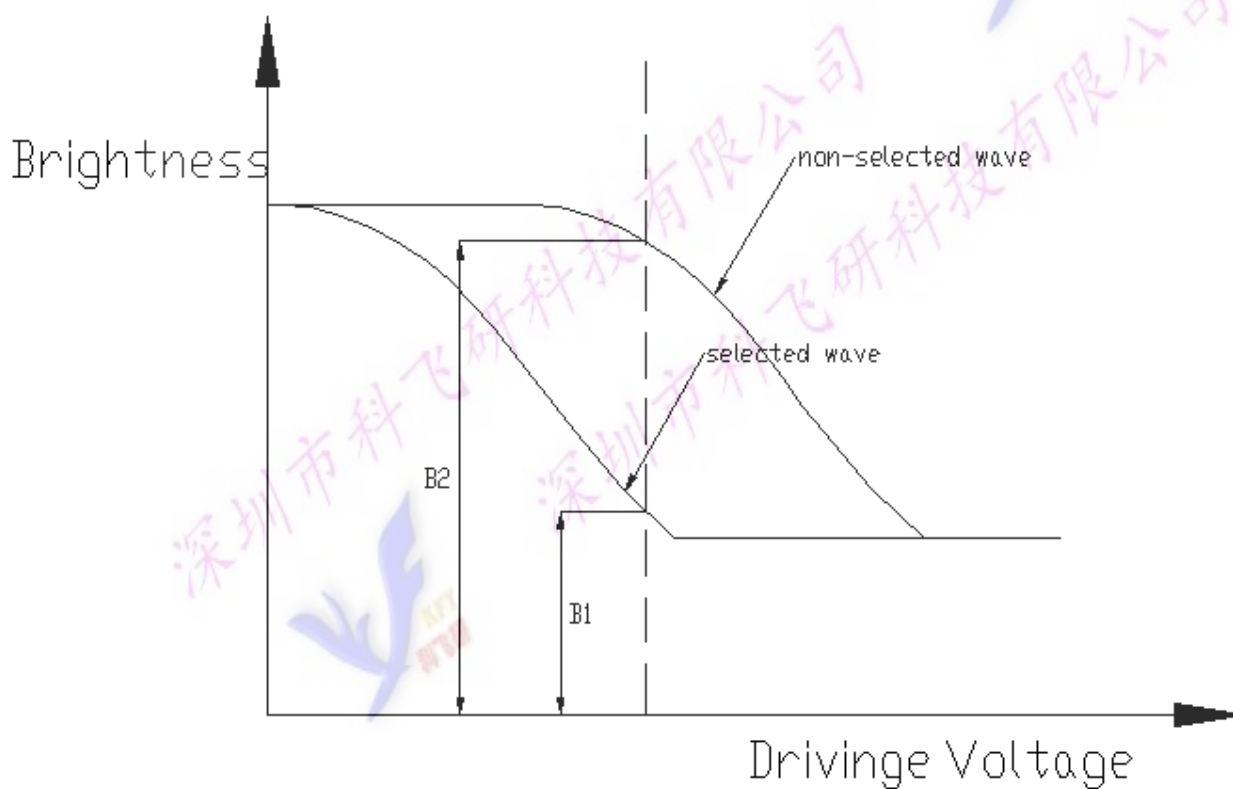

$$\text{Contrast Ratio}(K) = \frac{\text{non-selected state brightness}}{\text{selected state brightness}} = \frac{B2}{B1}$$

Measuring Conditions:

- 1) Ambient Temperature: 25°C; 2) Frame frequency : 32Hz

6.2.3 Definition of Response time (see fig. as follow)

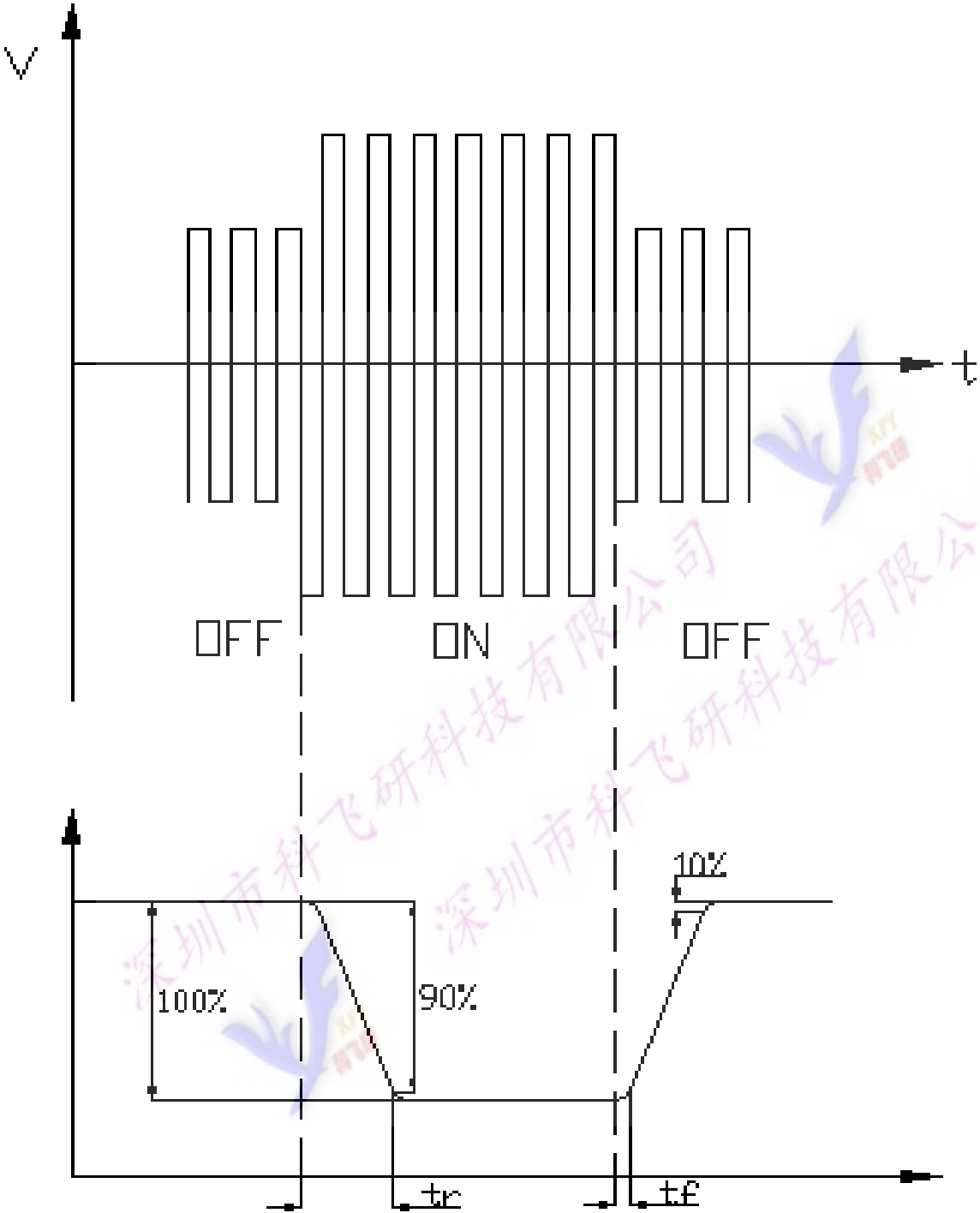

7 Reliability

7.1 Content of Reliability Test

NO.	Test Item	Content of Test	Test condition
1	High Temperature Storage	Endurance test applying the high storage temperature for a long time	60°C 96H
2	Low Temperature Storage	Endurance test applying the low storage temperature for a long time	50°C 96H
3	High Temperature Operation	Endurance test applying the Temperature electric stress (voltage & current) and the thermal stress to the element for a long time	50°C 96H
4	High Temperature Operation	Endurance test applying the Temperature electric stress (voltage & current) and the thermal stress to the element for a long time	0°C 96H
5	High Temperature /Humidity Storage	Endurance test applying the high temperature and high humidity storage for a long time	40°C 90%RH 96H
6	Temperature Cycle	Endurance test applying the low and high temperature cycle 10 cycle -20°C--25°C--60°C--25°C 30min 5min 30min 5min 1cycle	-20°C/60°C
7	Vibration Test (package state)	Endurance test applying the vibration during transportation	10Hz~55Hz ~10Hz 1.5mmP-P,1.5g X.Y.-5mm
8	Shock Test (package state)	Endurance test applying the shock during transportation	Drop a product form a height of 79cm to a solid unbending and horizontal plane
9	Atmospheric Pressure Test	Endurance test applying the atmospheric prssure during transportation by air	40kPa 24H

7.2 Failure Judgment Criterion

Criterion Item	Test Item NO.									Failure Judgement Criterion
	1	2	3	4	5	6	7	8	9	
Basic Specification	0	0	0	0	0	0	0	0	0	Out of the basic Specification
Electrical Specification	0	0	0	0	0					Out of the electrical specification
Mechanical Specification						0	0	0		Out of the mechanical specification
Optical Characteristic	0	0	0	0	0	0				Out of the optical specification
Remark	Basic specification = Display specification + Mechanical specification									

8. Precautions for use of LCD Modules

8.1 Handling Precautions

- 8.1.1 The display panel is made of glass. Do not subject it to a mechanical shock by dropping it from a high place, etc.
- 8.1.2 If the display panel is damaged and the liquid crystal substance inside it leaks out, be sure not to get any in your mouth, if the substance comes into contact with your skin or clothes, promptly wash it off using soap and water.
- 8.1.3 Do not apply excessive force to the display surface or the adjoining areas since this may cause the color tone to vary.
- 8.1.4 The polarizer covering the display surface of the LCD module is soft and easily scratched. Handle this polarizer carefully.
- 8.1.5 If the display surface become contaminated, breathe on the surface and gently wipe it with a soft dry cloth. if still not completely clear, moisten cloth with one of the following solvents:
- Isopropyl alcohol
 - Ethyl alcohol
- Solvents other than those mentioned above may damage the Polarizer. Especially, see the following:
- Water
 - Ketone
 - Aromatic solvents
- 8.1.6 Do not attempt to disassemble the LCD Module
- 8.1.7 NC terminal should be open. do not connect anything
- 8.1.8 If the logic circuit power is off, do not apply the input signals
- 8.1.9 To prevent destruction of the elements by electricity, be careful to maintain an optimum work environment
- a. Be sure to ground the body when handling the LCD
 - b. Tools required for assembly, such as soldering
 - c. irons, must be properly ground.

Modules

- d. To reduce the amount of static electricity generated do not conduct assembly and other work under dry conditions.
- e. The LCD Module is coated with a film to protect the display surface. Be care when peeling off this protective film since static electricity may be generated.

8.1.10 PRECAUTION FOR USING LCM

1. LIQUID CRYSTAL DISPLAY (LCD)

LCD is made up of glass, organic sealant, organic fluid, and polymer based polarizers. The following precautions should be taken when handling,

- (1). Keep the temperature within range of use and storage. Excessive temperature and humidity could cause polarization degradation, polarizer peel off or bubble.
- (2). Do not contact the exposed polarizers with anything harder than an HB pencil lead. To clean dust off the display surface. Wipe gently with cotton. Chamois or other soft material soaked in petroleum benzine.
- (3). Wipe off saliva or water drops immediately. Contact with water over a long period of time may cause polarizer deformation or color fading, while an active LCD with water condensation on its surface will cause corrosion of ITO electrodes.
- (4). Glass can be easily chipped or cracked from rough handling. especially at corners and edges.
- (5). Do not drive LCD with DC voltage.

2. Liquid Crystal Display Modules

2.1 Mechanical Considerations

LCM are assembled and adjusted with a high degree of precision. Avoid excessive shocks and do not make any alterations or modifications. The following should be noted.

- (1). Do not tamper in any way with the tabs on the metal frame.
- (2). Do not modify the PCB by drilling extra holes, changing its outline, moving its components or modifying its pattern.
- (3). Do not touch the elastomer connector, especially insert an backlight panel (for example, EL).
- (4). When mounting a LCM make sure that the PCB is not under any tress such as bending or twisting. Elastomer contacts are very delicate and missing pixels could result from slight dislocation of any of the elements.
- (5). Avoid pressing on the metal bezel, otherwise the elastomer connector could be deformed and lose contact, resulting in missing pie ls.

2.2. Static Electricity

LCM contains CMOS LSI's and the same precaution for such devices should apply, namely

- (1). The operator should be grounded whenever he/she comes into contact with the module. Never touch any of the conductive parts such as the LSI pads, the copper leads on the PCB and the interface terminals with any parts of the human body.
- (2). The modules should be kept in antistatic bags or other containers resistant to static for storage.
- (3). Only properly grounded soldering irons should be used.
- (4). If an electric screwdriver is used, it should be well grounded and shielded from commutator sparks.
- (5). The normal static prevention measures should be observed for work clothes and working benches; for the latter conductive (rubber) mat is recommended.
- (6). Since dry air is inductive to static, a relative humidity of 50-60% is recommended.

2.3. Soldering

- (1). Solder only to the I/O terminals.

- (2). Use only soldering irons with proper grounding and no leakage.
- (3). Soldering temperature: $280\text{ }^{\circ}\text{C} \pm 10^{\circ}\text{C}$
- (4). Soldering time: 3 to 4 sec.
- (5). Use eutectic solder with resin flux fill.
- (6). If flux is used, the LCD surface should be covered to avoid flux spatters. Flux residue should be removed after wards.

2.4. Operation

- (1). The viewing angle can be adjusted by varying the LCD driving voltage V_0 .
- (2). Driving voltage should be kept within specified range; excess voltage shortens display life.
- (3). Response time increases with decrease in temperature.
- (4). Display may turn black or dark blue at temperatures above its operational range; this is (however not pressing on the viewing area) may cause the segments to appear “fractured”.
- (5). Mechanical disturbance during operation (such as pressing on the viewing area) may cause the segments to appear “fractured”.

2.5. Storage

If any fluid leaks out of a damaged glass cell, wash off any human part that comes into contact with soap and water. Never swallow the fluid. The toxicity is extremely low but caution should be exercised at all the time.

